

2 Line Arrays for Miniaturized Spectrometers

The line array of a spectrometer is, besides the grating, the main parameter determining part. A suited choice of the array is vital for the proper adaption of the system to a certain application. The kinds of line arrays and their operation principles as well as issues for a correct selection are described in this chapter.

2.1 General Description

Line arrays are detectors with several individual readable sensitive areas, so-called pixels (picture elements), arranged in one straight line. They can be seen as “black boxes” transforming a spatially light distribution, in case of spectrometers the spectrum focus line, into a signal voltage or current distributed in time. This sequential output signal, the video signal, is further proceeded, mainly with an analog digital conversion as the first step.

The main parameters of line detectors are the following:

- Pixel number – the number of pixels arranged in the line
- Pixel dimensions – the pixel width and height [μm]
- Pixel pitch – the distance between the centers of two pixels [μm]
- Sensitivity – the wavelength dependent ratio of electrical signal output to the optical signal input [e.g. $\text{V}/\text{l}\cdot\text{s}$]
- Wavelength range – the range of wavelengths where the detector can “see” radiation [nm]
- Dark signal – the output signal without illumination of the detector [e.g. mV]
- Saturation exposure – the illumination level, at which the output signal stays constant with increasing illuminance [e.g. $\text{ml}\cdot\text{s}$]
- Linearity range – the illuminance range where the electrical signal output is proportional to the impinging energy [e.g. $\text{ml}\cdot\text{s}$]
- Dynamic range – the range in which the detector is capable of accurately measuring the input signal [10^x]
- Pixel non-uniformity – the output signal difference of the pixels under same illumination conditions [%]

Furthermore, the following issues are of interest for an application:

- the scheme of the operation pulses (every line detector needs several clocks for the read out operation)
- the thermal behavior of the array
- the image lag – a property of line detectors to “remember” the illumination of previous read out's

2.2 Types of Line Arrays

Currently, there exist three different types of line arrays, which are used in spectrographs: CCD, photodiode and CMOS arrays. They differ in their distinct production technologies and their parameters.

2.2.1 CCD Arrays

Principle of Operation

CCDs are array detectors with metal-oxide capacitors (photogates). During the illumination by the spectrum focal line a charge (electron – hole pairs) is produced under the gate. A potential well is created by applying a voltage to the gate electrode. The charge is confined in the well associated with each pixel by the surrounding zones of higher potential (see detail in fig. 10). The read out of the array is proceeded by a charge transfer by means of varying gate potentials according to special clock schemes. The charges of the pixels are transferred simultaneously to the shift register(s), followed by a sequential transfer to the output section, where the charge is converted into a proportional voltage. The node doing this is first set to a reference level (clamp level) and afterwards to the signal level. The difference is used as the final signal. This technique is called Correlated Double Sampling (CDS) and allows a significant reduction of the system noise.

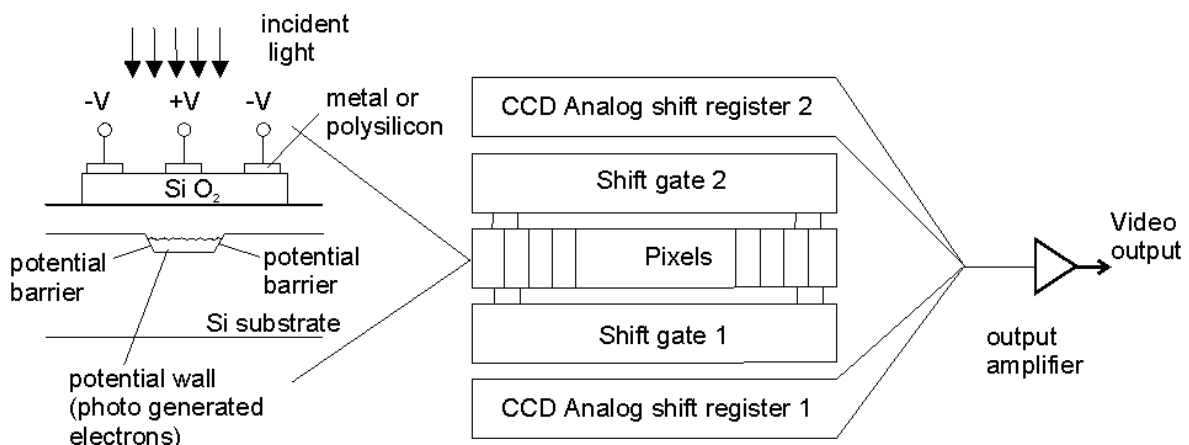

Fig. 10 Operation principle of a CCD array detector

Examples (see table at the end of this chapter)

There exists a wide variety of CCD arrays from several producers. The Sony ILX series is often applied in spectroscopy. Other types are the TCD 1201D of Toshiba and the S 703x series of Hamamatsu. The latter has not only one pixel line but also 122. It can be used in the so-called line-binning mode. The signals of each pixel row in the direction perpendicular to the spectrum are additionally combined to create a greater pixel height.

2.2.2 Photodiode Arrays (PDA)

Principle of Operation

Photodiode arrays consist of several photodiodes arranged in a line. The light energy impinging on a diode generates a photocurrent, which is integrated by an integration circuitry associated with this pixel. During a sampling period the sampling capacitor connects to the output of the integrator through an analog switch.

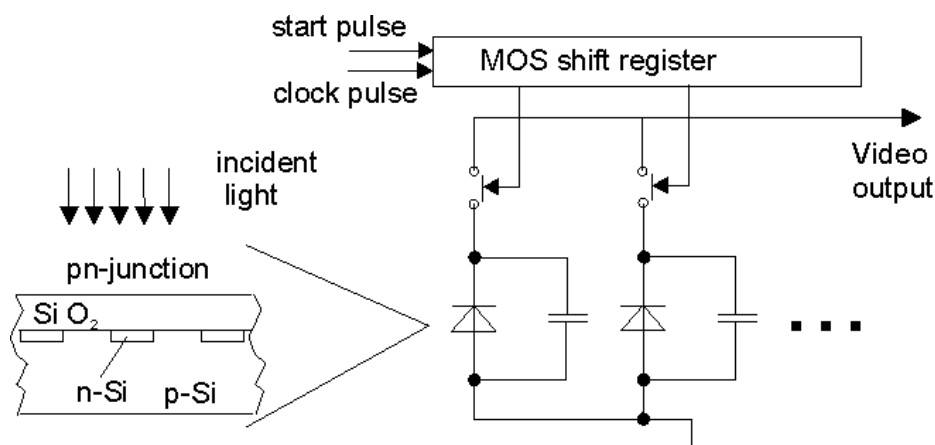

Fig. 11 Operation principle of photodiode arrays

There exist two different types of photodiode arrays which differ by kind of their output signal.

Current output arrays supply the recharge current of the depletion layer capacity as measuring signal. Therefore, an additional integrator is necessary. The relation between the peak value of this current and the integral is poor, so read out electronics based on the reading of the peak value are of lower quality. Especially with low saturation charge, it is difficult to measure the output correctly. A value of 1 pC equals about 10^7 electrons, with an electronic resolution of 16 bit one LSB is represented by only 1 000 electrons.

Voltage output arrays have the integrator on board and deliver a photon flux proportional voltage for the measurement. This causes fewer problems with the read out electronics.

Examples

Examples are the S 39xx and S 838x series of Hamamatsu as well as the MLX 90255 of Melexis and LF2C of IC Haus.

2.2.3. CMOS Arrays

Principle of Operation

CMOS arrays also use MOS structures as pixels like the CCD arrays. The basic difference is, that the charge-to-voltage conversion takes place directly in the pixel cell. This conversion consists again of two steps – the photon – electron and the charge (electron) – voltage conversion. This difference in read out technique has significant implications for the sensor architecture, capabilities and limitations. The following figure shows the scheme of a CMOS line array.

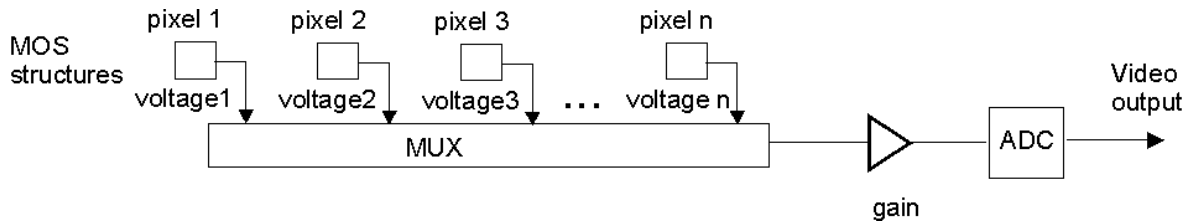

Fig. 12 Operation principle of CMOS arrays

CMOS arrays show better sensitivity than CCD's because it is easier to produce low power high gain amplifiers in CMOS technology.

Examples

The S 837x series of Hamamatsu and the L series of Reticon are examples for CMOS detectors.

2.3 Criteria of Selection for a Specific Application

As stated above, there are many parameters to consider for a proper selection of a line array for a specific application. Furthermore, it is necessary to weight the significance of the parameters because there is often no ideal choice possible.

Wavelength Range and Sensitivity

The detectable wavelength range of silicon-based arrays extends from 200 to 1100 nm, above this limit the photon energy is lower than the band gap energy. For longer wavelengths, InGaAs semiconductor material is used (up to 1.7 μm). Such arrays are relatively expensive. Furthermore, Si line arrays with anti Stokes Phosphor coatings are available. They are suited for the wavelength range up to approximately 1600 nm (depending on the material).

If we consider only silicon arrays there are also differences between the different types of arrays caused by the set-up and technical treatment. Mainly the extend of sensitivity in the range below 380 nm and above 800 nm differs significantly. The window material often is a limiting factor in the UV range. Therefore and due to the avoidance of additional Fresnel reflexes in the system detector, arrays in spectrometers are often used windowless.

The following figure shows the relative sensitivity of several line arrays.

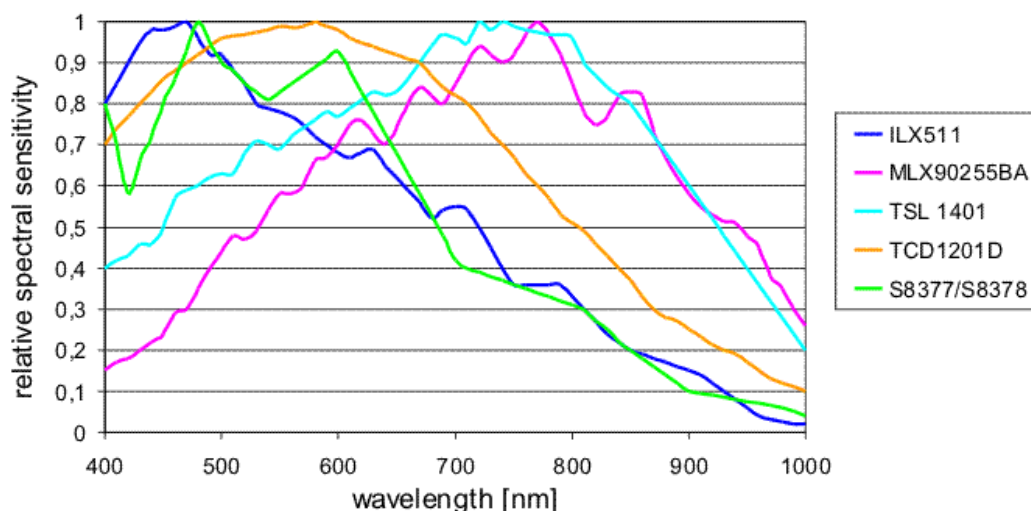

Fig. 13 Relative sensitivities of selected Si line arrays

The periodic modulation in many sensitivity curves is caused by white light interference on thin layers in the sensitive area and can be avoided by antireflexion coatings.

Typical absolute sensitivity values of different line arrays are shown in the following table:

Line Array	Typical Sensitivity
Hamamatsu S837x series	4.4 V/(lx·s)
Sony ILX 5x1 series	200 V/(lx·s)
TAOS TSL 140x series	25 V/($\mu\text{J}/\text{cm}^2 = 171 \text{ V}/(\text{lx}\cdot\text{s}) @ 550\text{nm}$
Toshiba TCD 1201D	80 V/(lx·s)
Melexis MLX 90255	1.3 V @ 10 $\mu\text{W}/\text{cm}^2 @ 0.7 \text{ ms}$
Reticon L series	$2.9 \cdot 10^{-4} \text{ C}/(\text{J}\cdot\text{cm}^2)$

Pixel Dimensions (pitch and height)

The pixel dimensions are an essential criterion for the selection of an array. The pixel width and pitch influence the digital resolution of a spectrometer and stand in relation to its optical resolution (see chapter 1.2.2.). Furthermore, it is necessary to adapt the pixel height to the height of the spectrum image. If the pixel height is too low, a part of the signal is lost and the efficiency of the system is low. On the other side a pixel height much larger than the spectrum height ends in an unwanted increased stray light influence. Some 2 – dimensional arrays allow a line binning for the virtual creation of a bigger pixel height.

The pixel line has to be precisely adjusted to the spectrometer focal line to avoid a strong thermal drift of the intensity output. Therefore, JETI offers a special light

source JLQ 1, which simultaneously emits three wavelength ranges in the blue, green and red into one fiber. The three outputs are controllable, this can be used with a precise mechanical positioning of the array in 3 directions (parallel and perpendicular to the pixel line as well as the angle between spectrum and pixel line) for a precise adjustment.

Dark Output

The dark output is a small electrical output of the line array without incident light. It is caused by thermal generation of carriers in the light sensitive elements, mainly due to Si – SiO₂ interface states. It has a strong correlation with the operation temperature. The dark output doubles for every temperature increase of 6 ... 10 K. Therefore, line arrays are cooled in low light level applications, e.g. in astronomic measurements.

Furthermore, the dark output depends on the integration time. Therefore, it is necessary in spectroscopic measurements to proceed a dark measurement at the same integration time which is used for the spectrum measurement. This can be done by a mechanical shutter (e.g. JETI spectroradiometer specbos 1201) or with a switched off light source (e.g. JETI colorimeter specbos 4001).

The dark output level of the spectrometer electronics has a relative niveau. It can be moved by the choice of gain and offset settings.

Saturation and Linearity Range

Saturation exposure is that level of photon intensity where the photon signal of the detector is no more dependent on the incident light flux. The value depends on the doping of the detector material. A rule of thumb is that a good linearity is achieved with photodiode and CCD arrays modulated between 0 and approximately 75 % of the saturation charge (exposure). Above this value the non-linearity raises significantly. The following figure shows the linearity behavior of a current and a voltage output photodiode array.

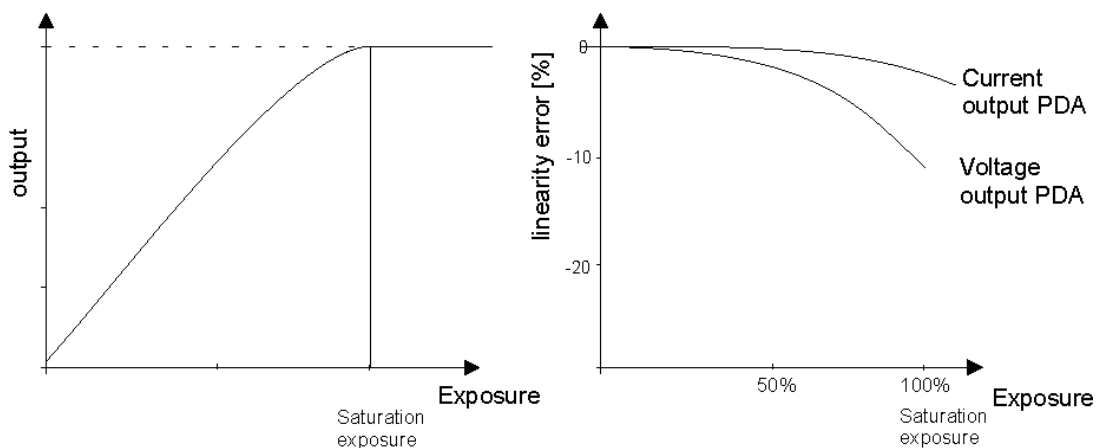

Fig. 14 Linearity behaviour of two line arrays (Hamamatsu)

The saturation exposure is given in the array data sheets, [mlx·s] and [nJ/cm²] are used as units, depending if it is seen from a photometric or a radiometric point of view.

The following table shows some values:

Line Array	Typical Saturation Exposure
Hamamatsu S 390x series	180 mlx·s = 26.3 nJ/cm ² @ 550 nm
Hamamatsu S 392x series	220 mlx·s = 32.1 nJ/cm ² @ 550 nm
Hamamatsu S 837x series	145/570 mlx·s = 21.2/ 83.2 nJ/cm ² @ 550 nm
Sony ILX 5x1 series	40 mlx·s = 5.8 nJ/cm ² @ 550 nm
TAOS TSL 140x series	92 ... 140 nJ/cm ²
TAOS TSL 1301	7 nJ/cm ²
Reticon L series	35 nJ/cm ²
PVs ELIS-1024	800 .. 6400 Ke ⁻ full well (dep. from selected pixel width)

Noise and Dynamics

There are two main categories of sources, which generate noise in a line array.

1. Fixed pattern noise
It consists of the dark noise and read out noise (e.g. due to internal switching). The fixed pattern noise is constant when the read out conditions are fixed and the integration time is not changed. So it is possible to eliminate it by subtraction from the measured signal.
2. Random noise
It is traceable to erroneous fluctuations of voltage, current or electrical charge, which are caused in the signal output process. If the fixed pattern noise is subtracted, the random noise determines the lower limit of light detection or the lower limit of the system dynamic range.

The dynamics is that range in which the detector is capable of an accurately measurement of the signal and is defined as the maximum detectable signal divided by the minimum signal level. The maximum detectable signal is limited by the detector saturation, the minimum signal by the noise of the system.

The dynamics depends on the integration time due to the thermal generation of noise.

Every kind of photon detectors only reaches a typical dynamics. Standard CCD arrays, like the Sony ILX 511, show a dynamics of 250 ... 300, related to full scale driving. If the spectrum has also regions with lower signal levels, the dynamics becomes even lower in these regions.

The dynamics of photodiode arrays is much higher. It depends on the operation regime and is determined by the analog multiplexer on chip and the integrators. Dynamics values of $> 3 \cdot 10^4$ can be reached with the Hamamatsu S39XX photodiode array series at room temperature, if it is used with a low noise integrator amplifier and a subsequent high performance 16 bit ADC. Photodiode arrays with integrator on board show a lower dynamics in main cases. An essential condition for a high dynamics is a high saturation charge of the array.

In case of minimum speed demanding applications it is possible to increase the dynamics by averaging.

Temperature Drift of Sensitivity and Dynamics

There are two effects, which cause a significant temperature dependence of the detector sensitivity: The absorption coefficient increases slightly with temperature. This effect increases the IR efficiency, but conversely decreases the UV efficiency. The second more significant effect is the exponential increase of the thermally excited electron-hole pairs with temperature. This leakage current doubles every 6 ... 10 K increase in temperature, connected with a raising noise.

Pixel Non-uniformity

The individual pixels of an array have different sensitivities caused by crystal flaws in the substrate and slight local variations in the wafer process. This uniformity is measured during a uniform illuminance of the sensitive area (50 % of saturation exposure) and calculation of the maximum deviation from the average value. Often the pixel non-uniformity is not of interest, especially if spectrometric systems are referenced. Thus the specific pixel differences are included in this reference.

Integration Time

The integration time is the main parameter for the user to adapt the modulation of a spectrometric system to the signal level of the measurement. In many applications it is necessary to have a linear relation between the integration time and the signal, especially in radiometric measurements.

Image Lag

The remain of charges on the PD/ CCD capacity or integrator is called image lag. It causes a virtual subsequent exposure if a dark measurement was done after a light measurement. Especially at CCD's, which came into saturation, several following read out cycles are necessary before the measurement results can be used.

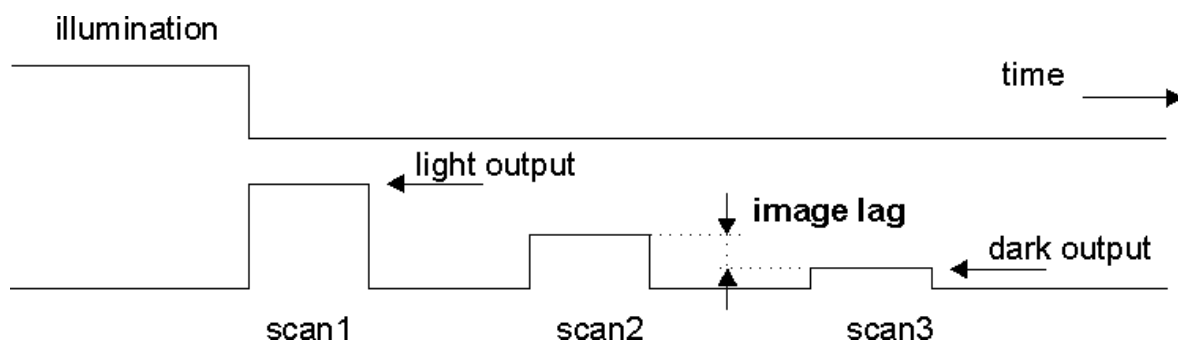

Fig. 15 Scheme of the image lag

2.4 Aspects of Read out Electronics

Types of Video Signals

The classical video signal originates from the TV technologies. The defined voltages are 1 V for the synchronization level, 0.75 V for black and 0 V for white. This video signal is called negative. Furthermore, all video signals have a positive offset voltage shifting the levels to higher values. CCD, like standard types of Sony (ILX series) and Toshiba are designed according to this classic standard.

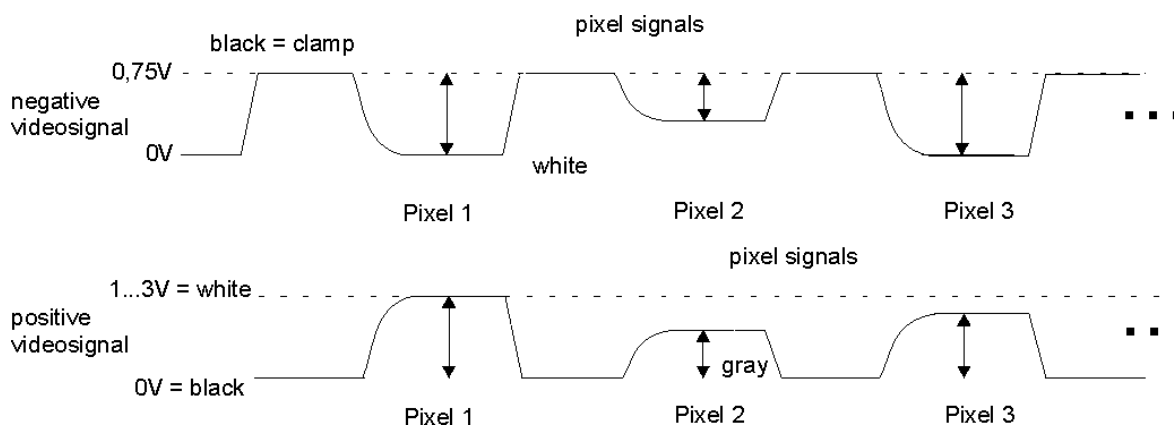

Fig. 16 Diagram of a negative and a positive video signal

Negative video signals often offer a so-called clamp level, which allows to set back the integrator to a defined offset voltage. So it is possible to use the clamp signal for a technique called correlated double sampling (CDS). One capacitor is loaded with the black level, the other one with the active video signal. The combination of both capacitors subtracts the charges. The result is a positive video signal for the ADC. Another solution uses two conversions of the black level and the active video signal and a following difference operation. This solution is much slower than the first one.

The AD conversion is mainly based on a positive ADC related to 0 V. Therefore, a positive video signal offers the advantage of a much simpler subsequent AD converter. Furthermore, an additional noise due to further amplifiers is avoided.

Main arrays, which have the integrator on board, offer a positive signal. Examples are the S837X series of Hamamatsu, the TSL series of TAOS and the arrays of Melexis and IC Haus.

Components of Line Array Read Out Electronics

A read out electronics for line arrays consists of the following main parts:

- Timing: The electronics needs to generate the necessary clock pulses for the array. These pulses differ from array type to type.
- Drive circuit: It serves for the operation of the shift registers.
- Signal processing circuit: It serves for the CDS and the amplification.
- AD converter: It transforms the analog signal to a digital level.
- Processor: It controls all processes and can be used for a precalculation of raw data.

- RAM memory: There can be stored system data (e.g. the pixel – wavelength fit – see chapter 1.2.7. or intensity calibration data - see chapter 3.4.) and measured data (e.g. dark signal or reference signal).
- Interface driver circuits: They manage the data transfer via different interfaces (e.g. USB, RS 232, parallel, CAN).

Reduction of Image Lag

An avoidance or significant reduction of the image lag effect can be reached by a continuous read out of the array, also before the start of the real integration time. JETI's electronic solution applies a fast scan modus, which is used to remove the remaining charge carriers in a short time. A disadvantage of this technique is that the pixels, which are read out first, have a slightly shorter integration time. Another technique is to read out the array continuously. In this case the measurement will be distorted after saturation. The fast scan mode results in a „cleaner“ photo capacitor.

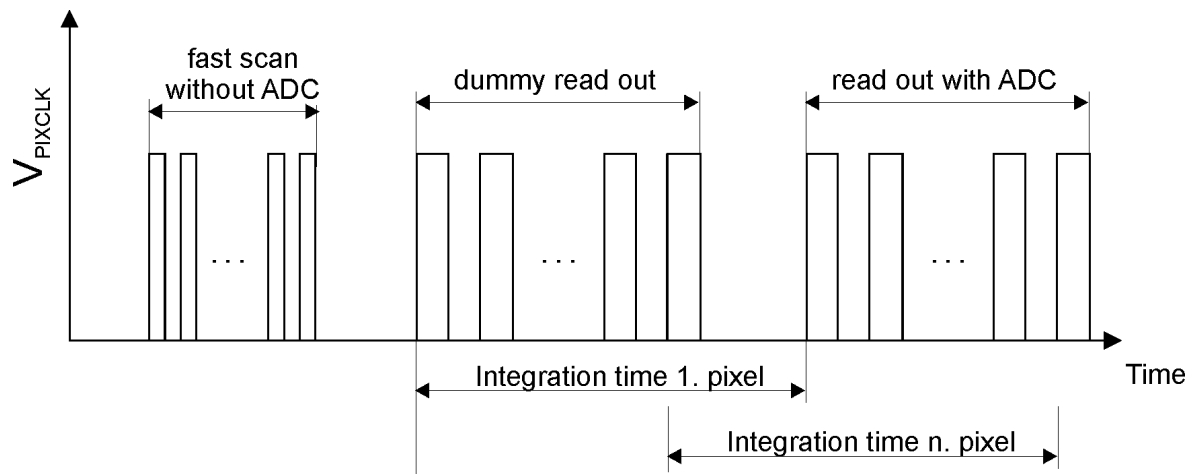

Fig. 17 Read out scheme of a detector array with fast scans

JETI offers several read out electronics for different line arrays. Some types are suited for more than one detector type, e.g. the VersaSpec board, shown in the following figure. It is suited for line arrays from HAMAMATSU: S390x, S837x, S9227, S70xx, S9840, ELIS 1024, Sony ILX-series and Toshiba TCD-series.



Fig. 18
Universal controlling electronics **VersaSpec**
for different photodiode and CCD detector arrays (example
Sony ILX571)

2.5 Examples of Line Detector Array

Producer	Type	Pixel area/ number	Technology	Remarks	Specific features
Hamamatsu	S390x series	50/ 25 μm x 2500/ 500 μm , 128/ 256/ 512	N-MOS (photo diode)	Current output	High UV sensitivity
	S392x series	50/ 25 μm x 2500/ 500 μm , 128/ 256/ 512/ 1024	N-MOS (photo diode)	Voltage output	High UV sensitivity
	S546x series	50/ 25 μm x 2500/ 500 μm , 256/ 512/ 1024	CMOS/ CCD		Integration amplifier on board
	S703 x series	24 μm x 24 μm , 512 x 122, 1024 x 122	CCD	Back illuminated	Line binning, high sensitivity (fluoresc. detection)
	S838x series	50/ 25 μm x 2500 μm , 128/ 256/ 512/ 1024	N-MOS (photo diode)		High VIS sensitivity
Sony	ILD5x1 series	14 μm x 200 μm , 2048 and more	CCD		Low dynamic range
TA OS	TSL140x series	63.5 μm x 55.5 μm , 128	Photodiode	128, 256, 512 and 1024 pixel types	Medium dynamic range
	TSL 1301	85 μm x 77 μm , 102	Photodiode		High sensitivity (fluoresc. detection)
To shiba	TCD 1201D	14 μm x 200 μm , 2048	CCD		Low dynamic range
Melexis	MLX 90255	66 μm x 200 μm , 128	Photodiode	similar to TSL1401, higher pixels	Integrated charge amplifier
Reticon	L series	50/ 25 μm x 2500 μm , 128, 256, 512, 1024	CMOS (Photodiode)		
IC Haus	IC-LFF1401	63.5 μm x 56 μm , 128	Photodiode	similar to TSL1401	
Photon Vision Systems	ELIS-1024	7, 8 ... 64, 4 μm x 125 μm	Photodiode		Electronically selectable pixel numbers (128/256/512/1024)

